

BANK

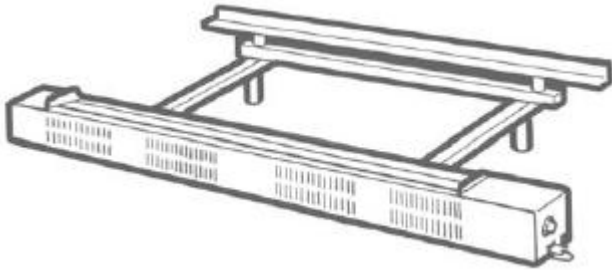

Table top monobending monolateral heating machine.

- Working length 1500 mm
- Opening from 5 to 35 mm
- Max. heating thickness 8 mm

TECNOLOGY FOR PLASTIC MATERIALS PROCESSING

The BANK heater has been designed and built to heat plastics such as PMMA, PC, PS and others, so they can be bent without streaking or burning the inside and outside the material.

The BANK heater has the unprecedented advantage of having a well outlined irradiated area, which allows executing both radiused folds and checking the length of the radius.

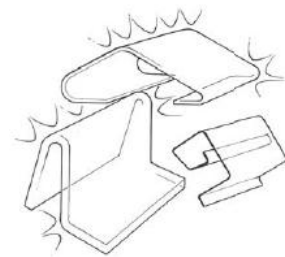

BANK 1500

Description	U of measure	1500
A	mm	1500
B	mm	1920
C	mm	6Min-40Max
D	mm	780
E	mm	120
F	mm	150

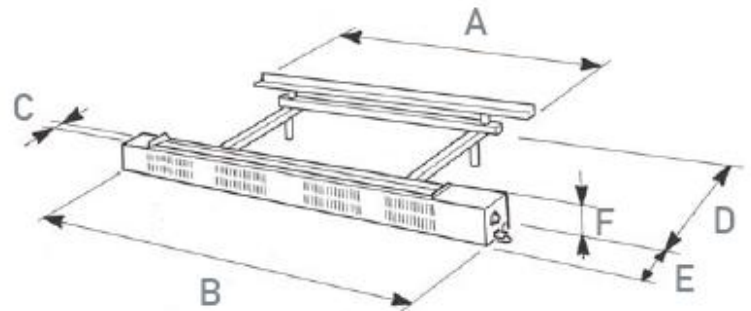

Description	Unit of measure	1G
Feeding	Volt	220
Max power	Watt	1500
Heated area		Min 6mm - Max 50mm
Minimum centers between two folds		Min 40 mm
Heating length	mm	1500
Cooling		Obbligatory
Weight	Kg	27

With the addition of the AUS group, the machine becomes a multibending machine: 2 - 3 - 4 folds at the same time, 40mm distance between centres.

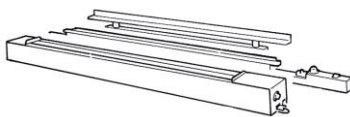

BANK 2

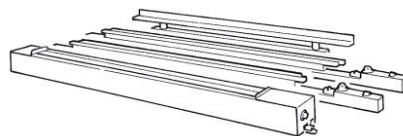

BANK 3

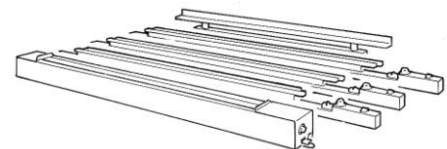

BANK 4

Separate adjustment of the heating units.